

## SMT Series - Aluminum Wound, Open Style Design

The SMT series is economical and compact with traditional open wound varnished coils. Ratings are from 1 KVA through 5 KVA with Class 180°C insulation system and **115°C rise** under full load. SMT transformers provide excellent cost benefits with NEMA regulation characteristics and electrical performance specifications.



### Features

- Available from 1000–5000 VA, 60 Hz unless noted
- Meets or exceeds electrical requirements of NEMA, ANSI, NMTBA and JIC
- UL Listed (File #E77014)
- CSA Certified (File #LR-14328-12)

### Related Products

- Linear Power Supplies
- DIN Rail DC Power Supplies
- Constant Voltage Transformers
- Line Reactors

### SMT Design Style

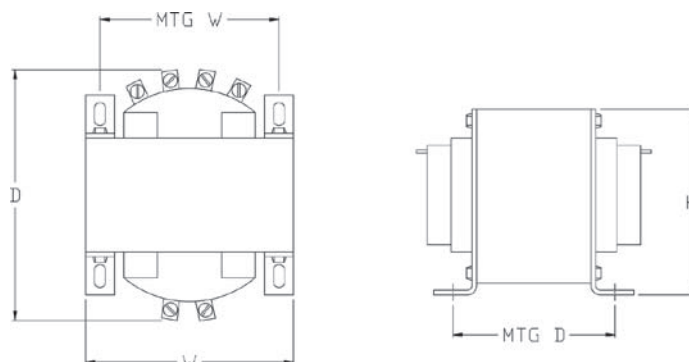

### Selection Table

**Group 1 – 240 X 480 Volt Primary, 120 Volt Secondary 60 Hz**  
**230 X 460 Volt Primary, 115 Volt Secondary 50/60 Hz**  
**220 X 440 Volt Primary, 110 Volt Secondary 50/60 Hz**

VA	Catalog Number	Height (inch)	Width (inch)	Depth (inch)	Mtg Width	Mtg Depth	Slot Size	Approx. Ship Weight (lbs)	
1000	T1000	5.63	6.38	6.38	5.31	4.25	.31 x .69	22	
1500	T1500	6.25	6.75	8.25	5.75	5.63	.44 x .69	28.3	
2000	T2000	6.25	6.75	9.13	5.75	6.63	.44 x .69	38.5	
3000	T3000	8	9	9.3	8	5.81	.44 x .69	55	
5000	T5000	8	9	11.3	8	7.5	.44 x .69	91	

Note: Fuse holders are not available for this voltage configuration.